

CMA-1, CMA-2 Angle Clamps, UB U-Bolt

Description:

The CMA-1 and CMA-2 are messenger angle clamps used with Hendrix Spacer Cable Systems. The clamps are cast ductile iron which are hot dip galvanized after fabrication.

Benefits:

- A material and labor cost savings alternative to messenger dead-end construction on angles
- Designed to work with Hendrix angle brackets for efficient installation

Application:

The CMA-1 clamp is designed for angles that pull away from the pole. The clamp will attach directly to the Hendrix BA4-15 angle bracket. When other Hendrix angle brackets are specified, the CMA-1 should be installed using a thru eyebolt. The CMA-2 clamp is designed for angles that pull towards the pole. The clamp should be attached to the BA4-15 angle bracket using a "U" bolt Hendrix Catalog No. UB.



CMA-1



CMA-2



UB

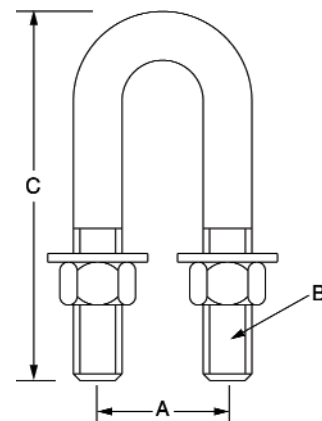
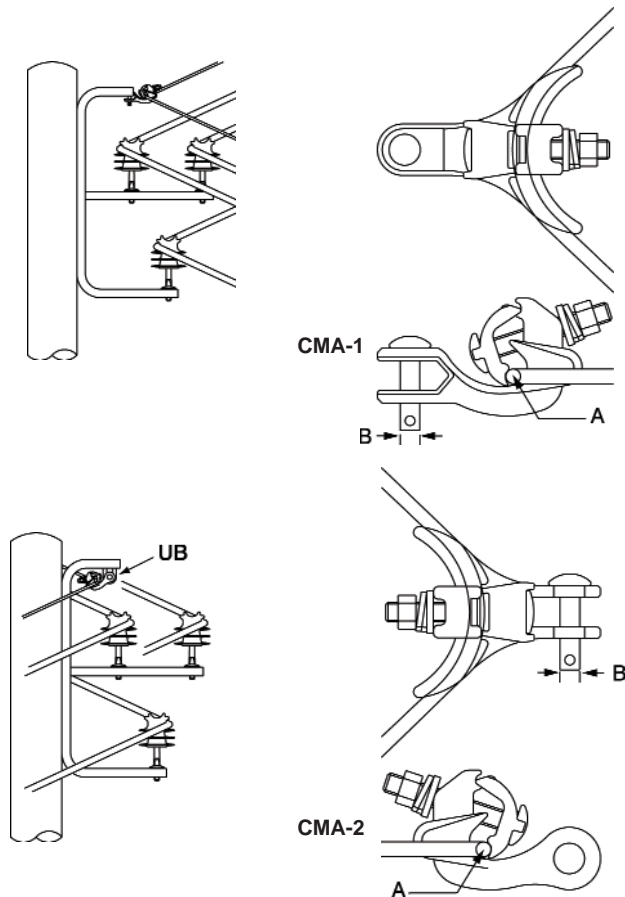

Catalog No.	Dimension (inches)			Max. Line Angle (degrees)	Min. Ultimate Load (lbs)	Weight (lbs)	Material
	A	B	C				
CMA-1	.23 -.75	$\varnothing \frac{5}{8}$	—	60°	11,000	2.4	HDG Ductile Iron
CMA-2	.16 -.75	$\varnothing \frac{5}{8}$	—	60°	11,000	2.1	HDG Ductile Iron
UB	1 1/2	$\frac{9}{16}$ -12 unc	4 1/4	—	—	1.1	Galvanized Steel