

# XPT-60, XPT-60H, XPT-75, XPT-75H Pole Top Extensions



## Description:

The XPT-60, XPT-60H, XPT-75 and XPT-75H are pole top extensions used with Hendrix Spacer Cable Systems. The brackets are formed using 3.0" channel and 2.0" angle and are hot dip galvanized after fabrication.

## Benefits:

- Eliminates the need for costly pole replacement
- Provides additional clearance between primary circuit(s) and under-built utilities
- XPT-60, XPT-60H extend pole up to an additional 44.0"
- XPT-75, XPT-75H extend pole up to an additional 59.0"
- 8.0" mounting hole spacing conforms to standard pre-drilled poles for ease of installation
- Brackets are designed to accept all Hendrix pole mounted hardware, eliminating the need for special construction standards

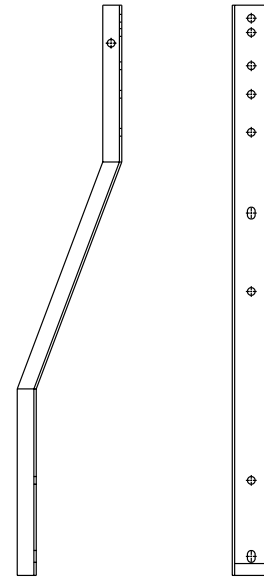

## Application:

The XPT-60 and XPT-75 are pole-top extensions that can be used on both tangent and angle structures where additional pole height is required. The XPT-60H and XPT-75H have two 3.0" channel sections to provide additional strength when required by circuit loading conditions. Contact Hendrix for assistance in selecting the proper pole top extension. Observance of proper guying practices is critical on angle structures. Hardware required for assembly of pole-top extensions is furnished. Pole mounting is accomplished using thru-bolts (not included).

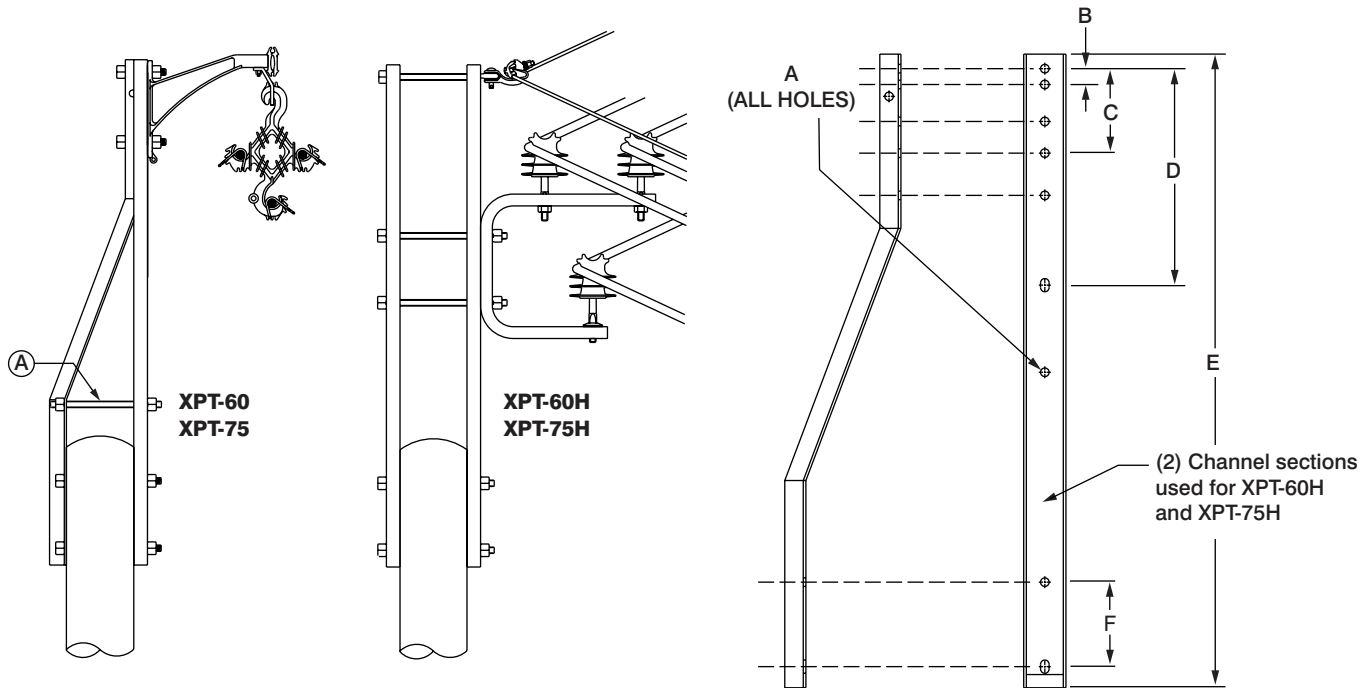

(A) - Double arming bolt supplied with XPT-75

Catalog Number	Dimension (inches)						Weight (lbs)	Material
	A	B	C	D	E	F		
XPT-60	1 3/16	1 1/2	8	20 1/2	60	8	41.5	ASTM A-36 Structural Steel
XPT-60H	1 3/16	1 1/2	8	20 1/2	60	8	56.0	ASTM A-36 Structural Steel
XPT-75	1 3/16	1 1/2	8	20 1/2	75	8	55.0	ASTM A-36 Structural Steel
XPT-75H	1 3/16	1 1/2	8	20 1/2	75	8	69.0	ASTM A-36 Structural Steel