

TMG Tubular Messenger Guide PAT-1 Angle Tensioning Block



Description:

The TMG and PAT-1 are designed to facilitate messenger installation on Hendrix Spacer Cable Systems. The Tubular Messenger Guide is cast aluminum bronze and is furnished complete with the hardware required for mounting on any of the Hendrix "BM" series tangent brackets. The Angle Tensioning Block is cast aluminum and is furnished complete with all required mounting hardware.

Benefits:

- Messenger can be tensioned while in the TMG and PAT-1
- The TMG locates the tensioned messenger so that the MC-2 messenger clamp can be installed, and the messenger clamped, without moving the messenger or removing the Tubular Messenger Guide
- The PAT-1 is a less expensive alternative to standard, single sheave roller blocks
- The TMG and PAT-1 are available on a rental basis, minimizing the investment in installation equipment

Application:

The TMG is designed to be mounted on all Hendrix "BM" series tangent brackets and is used to install messenger on line angles 6° and below. CAUTION: The MC-2 Messenger Clamp must be removed when pulling in the messenger. When the messenger is installed and properly tensioned, the MC-2 Messenger Clamp is installed, the messenger is clamped, and the TMG is then removed.

The PAT-1 is used for messenger installation on all angles greater than 6°. The Angle Tensioning Block is used in the same manner as any single sheave roller block.



TMG



PAT-1

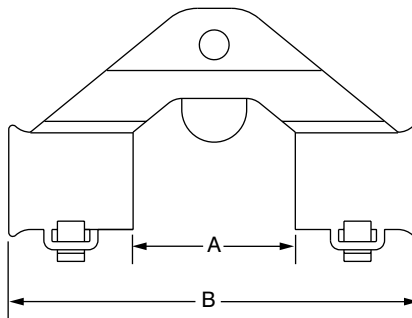
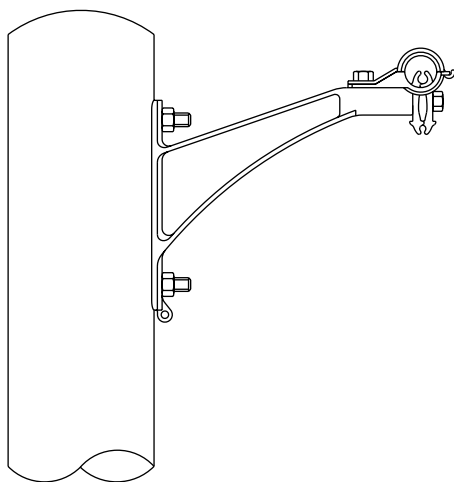

TMG

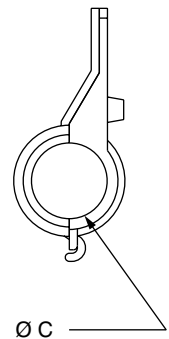

Ø C

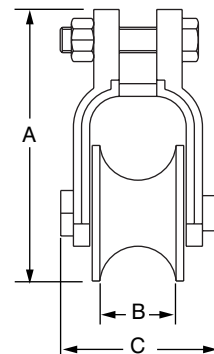

PAT-1

Catalog Number	Dimension (in)			Weight (lbs)	Maximum Load Rating (lbs)	Material
	A	B	C			
TMG	3 ¾	8 ½	1 ¾	4.2	—	Aluminum Bronze
PAT-1	6 1/16	1 7/8	3 7/8	2.5	5,000	Cast Aluminum